



Founded in 1946

Project: \_\_\_\_\_

Items: \_\_\_\_\_

Quantity: \_\_\_\_\_

Approval: \_\_\_\_\_

Date: \_\_\_\_\_

## Picking Tow Cart

The Picking Tow Cart offer a durable, space-efficient solution for transporting orders. Ideal for fulfillment centers, they feature dual shelves, smooth maneuverability, and a sturdy steel build with a sleek powder-coated finish.

### Features:

- Constructed of all welded steel
- Powder coated gray
- Two solid shelves doubles the capacity, each supported by a tubular frame
- Maneuvers easily on (2) swivel and (2) rigid 5" polyurethane casters
- Base Load Capacity: 500 - 1100 lbs

### Benefits:

- High end handles keep totes and merchandise in place, minimizing the risk of shifting or damage during transit.
- Link multiple carts together to boost order processing.
- Integrated pull handle allows for smooth and controlled maneuvering, even in tight spaces.
- Built-in chalkboard writing surface makes it easy to identify merchandise and locations, improving inventory accuracy.



SC-2-2149-MO





Founded in 1946

# Picking Tow Cart

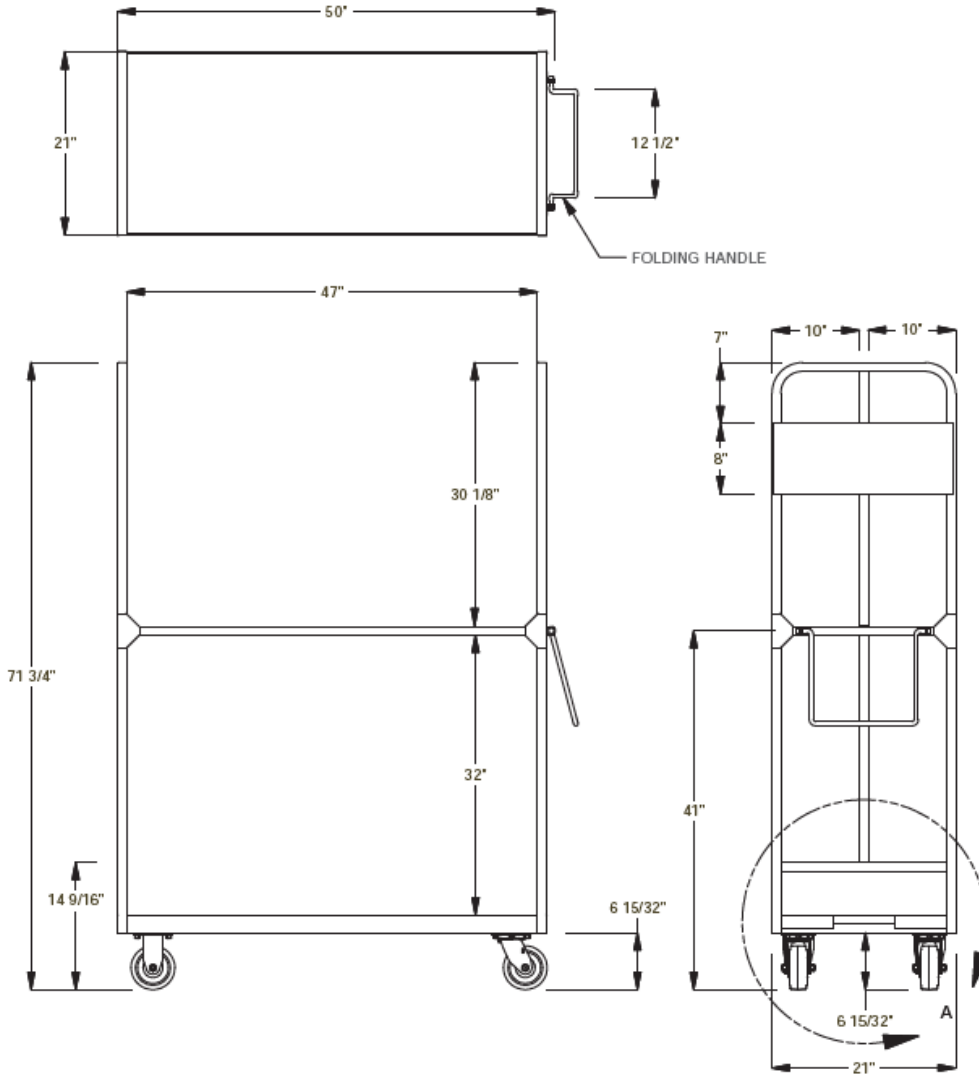
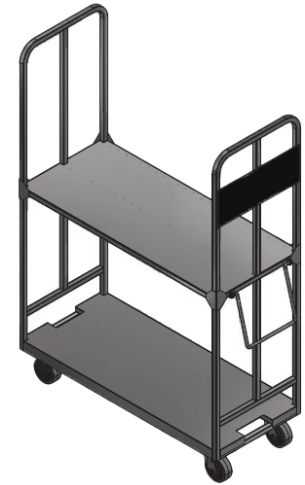

Model Number	Order#	Overall Dimensions			Approx. Ship Wt (lb)
		Width (in)	Length (in)	Height (in)	
SC-2-2149-MO	1141970	21	50	71 3/4	145

**Caster Information:**

- (2) Swivel Plate Casters with 5" Polyurethane Wheel 738AW
- (2) Rigid Plate Casters with 5" Polyurethane Wheel 743W

**Freight Class: 250**



As part of our commitment to continuous product improvement, Winholt reserves the right to modify materials and specifications without prior notice.