



Project: _____

Items: _____

Quantity: _____

Approval: _____

Date: _____

On-Line Order Picking Work Station

Multi-Faceted Order Picking Cart, loaded with features, an all in one work station. Streamlines the picking process and increases production.

Features:

- Constructed of all welded aluminum
- Powder coated red
- Includes printer basket, utility shelf, bag holder, label roll rod, paper towel rod, and water holder.
- Holds 6 lugs for order picking: approximately 22" L x 15.25" W x 10" H (not included).
- Weight Capacity: 40lbs per tote

Benefits:

- Solid top offers additional working area.
- Vinyl grip handles assist in maneuvering the cart with ergonomic design.
- Light weight
- Easily maneuvered



ALTPC-2536-MO





On-Line Order Picking Work Station

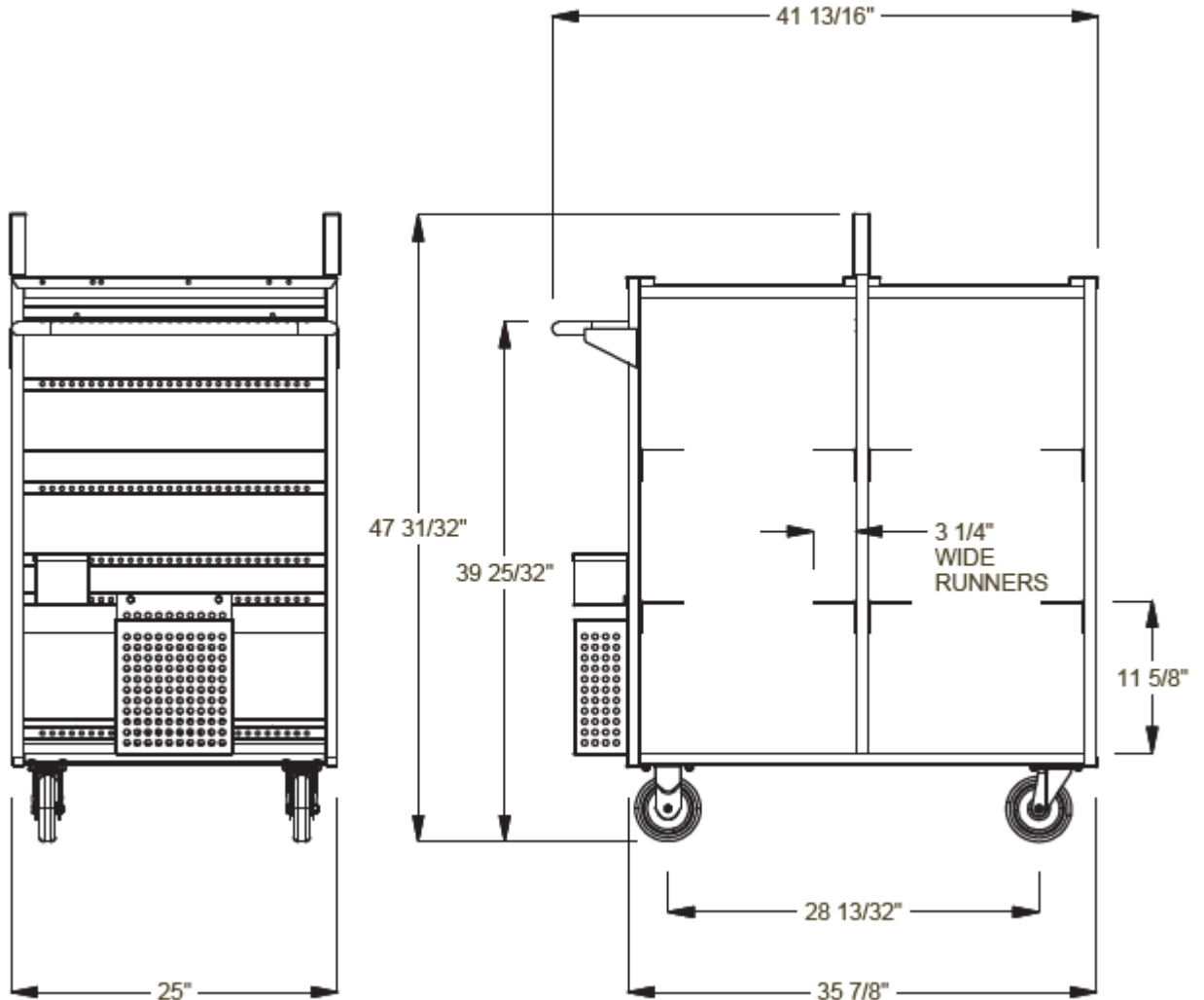

Model Number	Order#	Overall Dimensions			Approx. Ship Wt
		Width	Length	Height	
		(in)	(in)	(in)	(lb)
ALTPC-2536-MO	1141967	25	42.75	36.75	52

Caster Information:

- Swivel Plate Caster with 5" Polyurethane Wheel & Brake 738AW/LC
- Rigid Plate Caster with 5" Polyurethane Wheel 743W
- 5" Polyurethane Wheel 7112

Freight Class: 250



In line with our policy to continually improve our products, Winholt reserves the right to change materials and specifications without notice.