



Founded in 1946

Project: _____

Items: _____

Quantity: _____

Approval: _____

Date: _____

FORKLIFTABLE CAGED CART

Forkliftable Caged Cart w/ Folding Shelves

This Forkliftable Caged Cart reduces manual labor for warehouses and distribution centers. Our sturdy steel design makes forklift maneuvering safe and easy. The perfect solution for e-commerce fulfillment order picking.

Features:

- Welded heavy duty steel construction, powder coated gray
- 16 Gauge expanded metal enclosure, caged on three sides to prevent merchandise from falling off the cart. Back of the unit opens for easy unloading.
- Non-skid safety surface on the base of the cart and step
- (6) Shelves fold up to accommodate a variety of different sized packages
- Load Capacity: 3000 lbs
- (2) Swivel 5" polyurethane casters with brakes
- (2) Rigid 5" polyurethane casters

Benefits:

- All welded heavy duty steel construction is sturdy and allows for extensive use in harsh conditions.
- Metal enclosure on three sides provides protection against damage to items.
- The ability to lift the cart with a forklift facilitates fulfillment and saves time.



CENT-EC-1

We offer a variety of other models and sizes, just right for your operation.

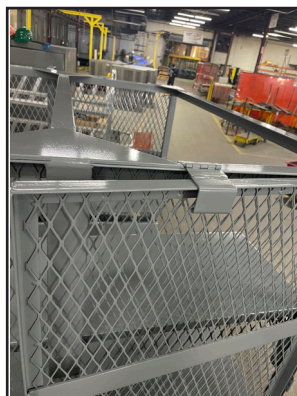



Forkliftable Caged Cart w/ Folding Shelves

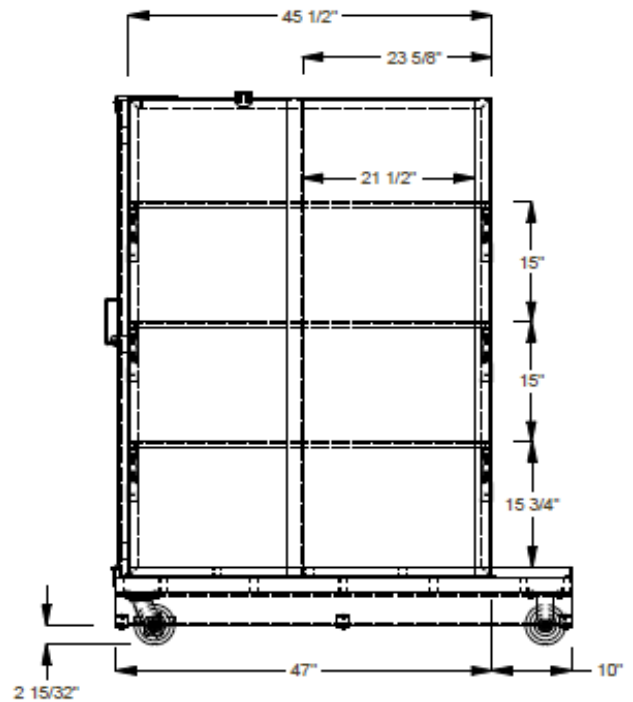
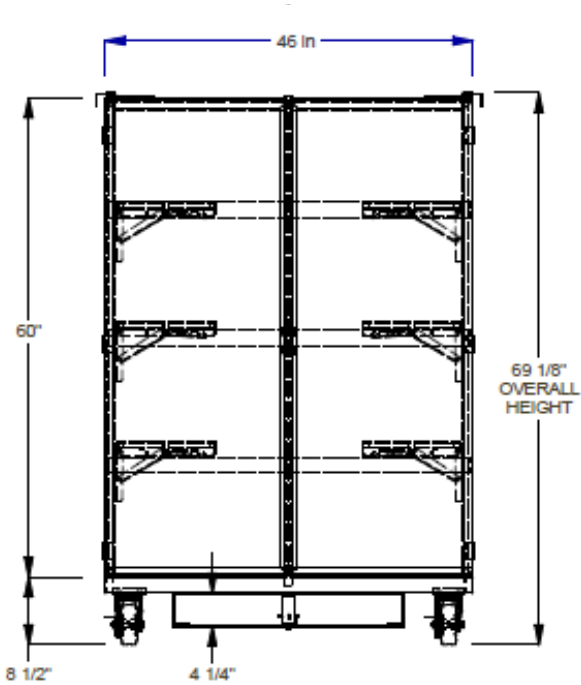
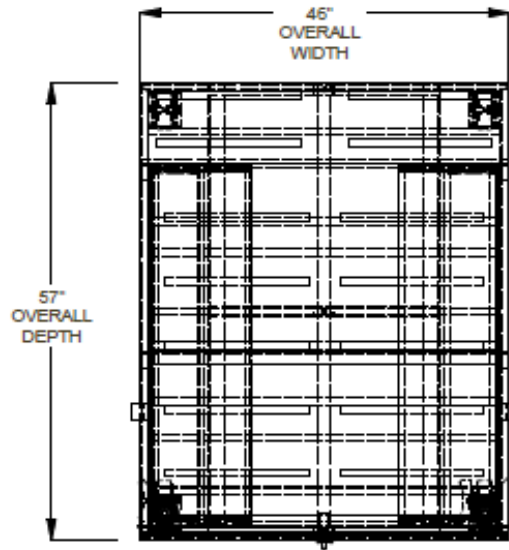

Model Number	Order Number	Overall Dimensions			Approx. Ship Wt (lb)
		Width (in)	Length (in)	Height (in)	
CENT-EC-1	1150122	46	57	69.1	494

Caster Information:
 (2) Rigid 5" x 2" Polyurethane
 (2) Swivel 5" x 2" Polyurethane with Brake
Freight Class: 250



In line with our policy to continually improve our products, Winholt reserves the right to change materials and specifications without notice.