



Founded in 1946

Project: _____

Items: _____

Quantity: _____

Approval: _____

Date: _____

Medium Duty Steam Pan Racks

Proof, store, and transport full, half, or third size pans with Winholt Steam Pan Racks.

Features:

- Available in all welded aluminum (AL) or stainless steel (SS)
- Runner angle 1" x 1.5"
- **Lifetime Warranty Against Rust**
- Holds 12" x 20" steam table pans
- Holds full, half, and third size pans
- Rolling Capacity: 800 lbs
- Weight Capacity per Runner: 30 lbs

Benefits:

- Ideal for volume production of food stored in steam table pans.
- Maintains sanitary environment in the kitchen
- Aluminum and stainless designs are sturdy and reliable.
- Safely and efficiently transport items



ALSPR-1320



Founded in 1946

Medium Duty Steam Pan Racks

ALSPR-1320 Specs

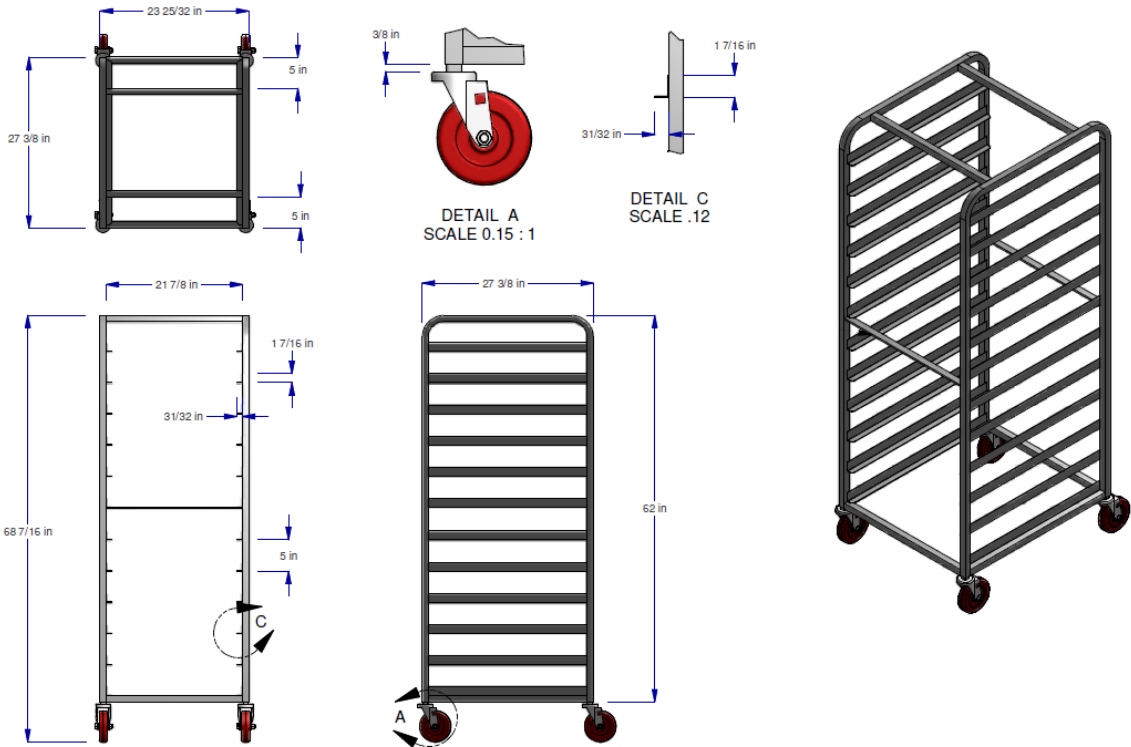

Model Number	Order#	Overall Dimensions						Pan Capacity	Runner Spacing	Approx. Ship Wt			
		Width		Length		Height				18" x 26"	(in)	(lb)	(kg)
		(in)	(mm)	(in)	(mm)	(in)	(mm)						
Loads on the 20" Side (Side Loads) - Holds 2 Full Size Pans Per Ledge													
ALSPR-2212	382387	23.9	607	27.4	696	68.5	1740	12	5	30	13.61		
ALSPR-2220	382395	23.9	607	27.4	696	68.5	1740	20	3	42	19		
Loads on the 12" Side (End Loads) - Holds 1 Full Size Pan Per Ledge													
ALSPR-1320	157788	13.9	353	22.4	569	68.5	1740	20	3	55	24.9		
SSPR-1320	382408	13.9	353	22.4	569	68.5	1740	20	3	81	36.7		
Double Wide - Loads on the 12" Side (End Loads) - Holds 1 Pan Per Ledge													
ALSPRD-1320	382424	30.75	781	22.4	569	68.5	1740	40	3	81	36.7		

Caster Information:

(4) 5" Polyurethane Casters 757

Freight Class: 250



In line with our policy to continually improve our products, Winholt reserves the right to change materials and specifications without notice.