



Project: \_\_\_\_\_  
Items: \_\_\_\_\_  
Quantity: \_\_\_\_\_  
Approval: \_\_\_\_\_  
Date: \_\_\_\_\_

## Distribution Tow Cart

Designed with logistics in mind, this unit optimizes the movement of materials to and from distribution hubs, supporting streamlined supply chain practices.

### Features:

- Constructed of all welded steel, powder coated
- Shelves fold up and are held with slotted hinges
- Clear front document holder on left side
- Left side of cart folds up for nested storage
- Shelf load capacity: 500 lbs
- Total load capacity: 1000 lbs
- Retractable sign holder to label carts and destination locations.
- Optional shelf dividers that swing to the back of the unit for storage
- Swing handle
- Tow hitch folds up when not in use.
- Maneuvers easily on 5" polyurethane casters, (2) rigid and (2) swivel with brakes

### Benefits:

- Shelves easily fold up, sides fold, and units can be nested for storage.
- Shelf spacing can be altered depending on the dimension of the items being placed on the shelves.
- Tow hitches allow for easy movement of the carts without much effort.
- Retractable sign holder allows for signs to be placed for distinguished trucks.
- Optional shelf dividers keep items in place and organized
- Promotes lean and safe operations for associates.

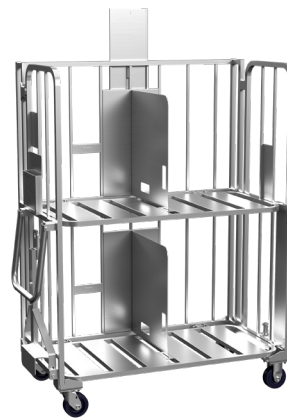

Shown with Optional Dividers





Founded in 1946

# Distribution Tow Cart

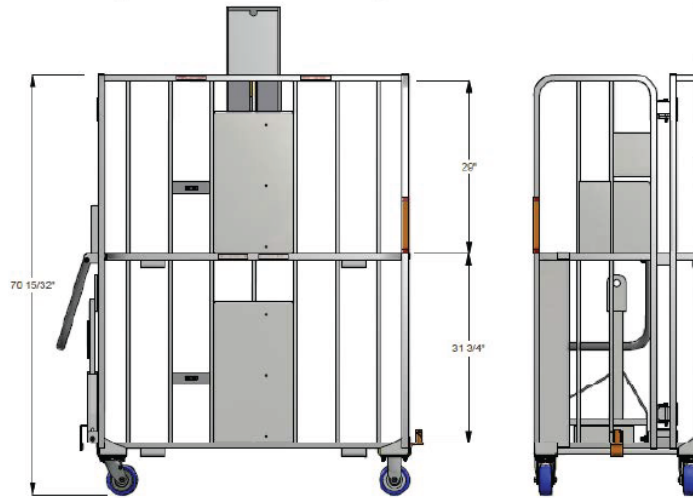
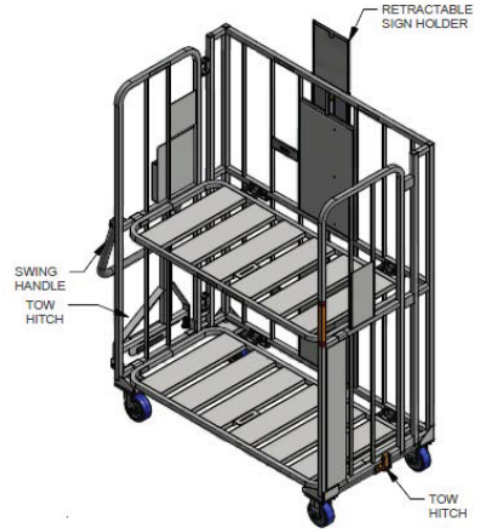
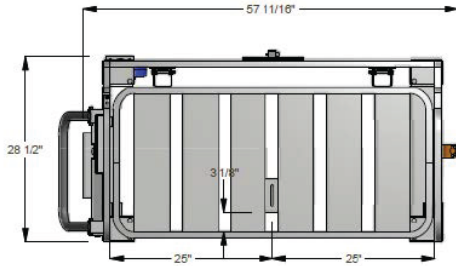

Model Number	Order #	Overall Dimensions			Approx. Ship Wt (lb)
		Width (in)	Length (in)	Height (in)	
DC-2852TOW-2S-SLV	1098417	28.5	57.7	70.5	272

**Caster Information:**

(2) 5" Polyurethane Swivel Caster with Brake 7318

(2) 5" Polyurethane Rigid Caster 7414W

**Freight Class: 250**



In line with our policy to continually improve our products, Winholt reserves the right to change materials and specifications without notice.