

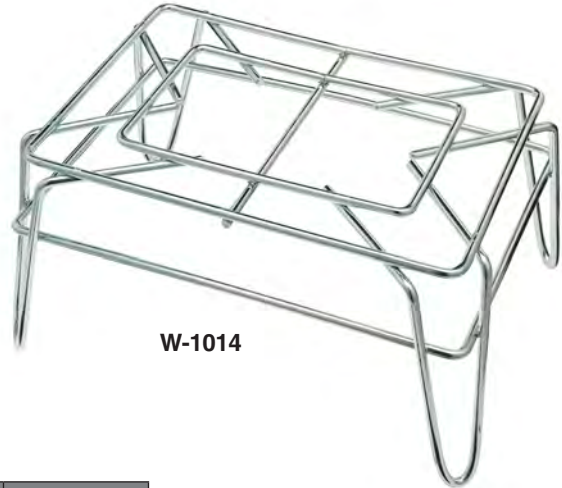

MERCHANDISE DISPLAY STANDS DOUBLE & SINGLE

- Material: All welded, plated, heavy duty, steel wire
- Maximizes product visibility and enhances customer impulse buying.
- Elevates products off the ground allowing the area underneath to be cleaned for more sanitary conditions.
- Nests for storage and freight savings.



W-1014

Highlights products and merchandise in aisle.

Multiple units can be used the length of the aisle to increase impulse sales.

Model Number	Order#	Overall Dimensions			Capacity	Approx. Ship Wt
		Width (in)	Length (in)	Height (in)		
W-1014	108231	10	14	8	500	5
W-2414	624366	14	24	8	850	8

Freight Class: 125

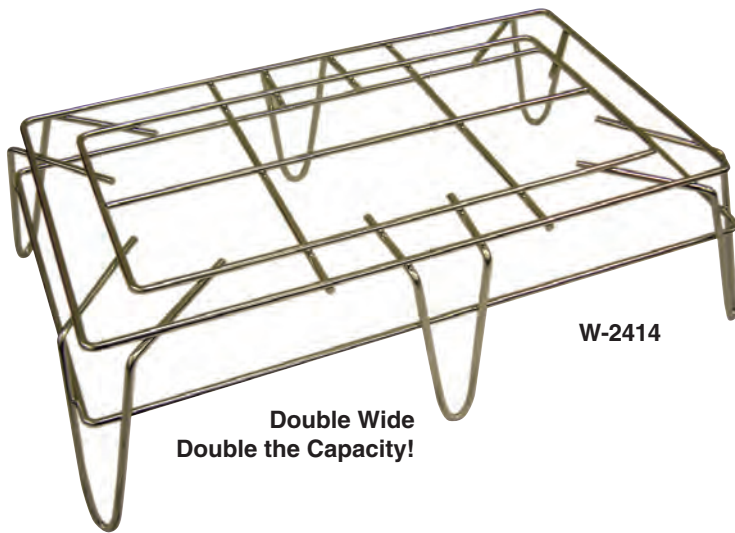

W-2414

**Double Wide
Double the Capacity!**

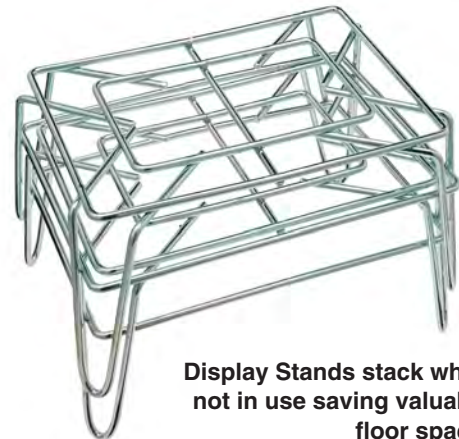

Display Stands stack when not in use saving valuable floor space!